

# VALLEY TRACTOR PULLERS ASSOCIATION INC.

(V.T.P.A)

---

---

**Valley Tractor  
Pullers  
Assn.**



**2009 OFFICIAL RULE BOOK**

**TRACTORS**

P.O. Box 1304  
Turlock, California 95380

[www.vtpapullers.org](http://www.vtpapullers.org)

# 2009 OFFICERS and DIRECTORS

---

---

## OFFICERS

President

**Chris Fagundes**

Secretary

**Dick Piersma**

Vice President

**Dino Avila**

Treasurer

**Kelly Luth**

## DIRECTORS

1 Year Term

**Arnold Avila**

**Dirk Piersma**

**Jack Soares**

**Alvin Wills**

2 Year Term

**Don Freitas**

**Joe Gonsalves**

**Joe Terra**

**Leland White**

## TECH TEAM

**Don Freitas**

**Clifford Gillit**

Changes for the 2009 season are highlighted.

# VALLEY TRACTOR PULLERS ASSOCIATION

## 2009 OFFICAL RULES - GENERAL MEMBERSHIP

Valley Tractor Pullers Association is a Tractor Pulling Club. VTPA recognizes the need for rules and regulations to promote safe, fair and competitive Tractor Pulling. VTPA members have the responsibility to spectators and fellow members to present a unified effort in competitions.

Membership dues have been set by the Board of Directors at \$50.00 for the pulling season. Dues are due January 1<sup>st</sup>. and delinquent after January 15<sup>th</sup>. Late dues are \$75.00 (does not apply to new members) and must be paid by March 1<sup>st</sup>, or membership will be forfeited.

### SECTION I: ELIGIBILITY OF CONTESTANTS

1. All contestants competing in any vehicle pulling contest sanctioned by VTPA must have a current competing membership in VTPA in order to compile points for high point's award. Contestants must be 16 years of age for all open classes or at least 12 years of age for all antique and stock classes. -Contestants 17 years of age or younger, must have parents or legal guardian's signed consent and supervision at all times throughout the pull.
2. Membership:  
Any individual upon payment of specified dues for a calendar year and who have met the criteria listed below, will be awarded membership with two-thirds (2/3) majority vote at a General Membership meeting.
  - A. Be nominated by a current member in good standing and submit an application.
  - B. Nomination and application will be reviewed by the Board of directors at the next scheduled Board meeting.
  - C. If approved by the Board of Directors, the prospective member will attend a general meeting and members will vote to accept, or not accept the candidate as a member.
  - D. Membership will begin upon approval by the members and receipt of dues.
  - E. Membership will be probationary for one full season.
  - F. If the candidate becomes a member during the pulling season, the probationary period will last for the rest of that season and for one full season after that.
  - G. Once the probationary period is completed, the Board of Directors will grant or deny permanent membership status after a review.
  - H. New members may be denied membership based on class size (too many in a class).
  - I. Classes may be limited in size (numbers) at the discretion of the board.
3. Any VTPA member or vehicle may compete in a tractor pull not sanctioned by VTPA provided the other pull is NOT in direct conflict with a VTPA sanctioned pull or member will be suspended and lose all points for one year and one month. Exceptions to this rule can only be approved by the Board of Directors. (Suspension means NO participation in any event: NO EXCEPTIONS).
4. The Board of Directors may, on occasion, declare a pull to be limited entry. In this situation, the event coordinator is directed to accept contestants from VTPA competing memberships only, provided such members Vehicle has participated in at least 25% of immediately prior events.

5. There must be (1) “throw-away” pull per season. A disqualification (DQ) at a regular event cannot be used as a throw-away pull.

## **SECTION II: OPERATION OF CONTEST**

### **COMPETITOR CONDUCT**

1. All vehicles must be operated in a safe manner at all times within the confines of the pits, staging areas and track. The tech officials have the right to stop and disqualify (DQ) any vehicle not being operated in a safe manner. The track judge has the right to stop and (DQ) any vehicle not being operated in a safe manner on the track and staging areas.
2. Drivers must remain seated during the pull and must have complete control of the vehicle at all times.
3. Only the driver will be allowed on a vehicle at any time: NO riders allowed. Anyone other than a driver on a vehicle will mean an automatic DQ.
4. Any Driver found to be intoxicated will not compete for the duration of the pull and must find another driver for their vehicle. A second infraction of this rule will be sufficient grounds for disqualification and loss of points to date.
5. Any person displaying unprofessional and/or unsportsmanlike behavior, including but not limited to abusive or obscene language, and/or physical action towards event officials, fellow competitors or spectators, or causes deliberate delay of the event, will be disqualified from the event. A second infraction of this rule will be sufficient grounds for disqualification and loss of points to date.
6. All pullers must wear shirts, pants or shorts, and closed toed shoes (no open toed shoes allowed) before being allowed to compete.
7. Any member that knowingly commits any act that proves to be detrimental to the association, as determined by the board of directors, may be removed from the membership and refused participation in any event.

### **ENTRY PROCEDURE POLICY**

1. Entry fees per class for VTPA members will be \$20.00: Entry fees for non-members will be \$40.00. Each vehicle entered will receive 2 free pit passes.
2. Members must be entered for position by entry meeting day. Members entering on the day of the pull will get Hook Points only. Non-members may enter on the day of the pull and take last pulling order if time allowed.
3. Each vehicle can be entered in one (1) class only, and only once (1) in each class.

## EVENT PROCEDURES and POINTS

1. Placement points will be awarded as follows:

Finish	Points	Finish	Points	Finish	Points
1 <sup>st</sup>	1000	6 <sup>th</sup>	450	11 <sup>th</sup>	200
2 <sup>nd</sup>	750	7 <sup>th</sup>	400	12 <sup>th</sup>	190
3 <sup>rd</sup>	600	8 <sup>th</sup>	350	13 <sup>th</sup>	180
4 <sup>th</sup>	550	9 <sup>th</sup>	300	14 <sup>th</sup>	170
5 <sup>th</sup>	500	10 <sup>th</sup>	250	15 <sup>th</sup>	160

2. Placement points will be given to members' vehicle only. (Driver must be a member in order for vehicle to receive points.
3. Points are awarded to vehicle entered and are not transferable from class to class but vehicle with points can be transferred from one owner to a new owner that is a member.
4. In order to receive VTPA placement points, the contestant must hook and make a measurable pull under a green flag.
5. Each vehicle hooking to the sled will be awarded and additional (100) Hook Points.
6. To be eligible for high points award and second place, members vehicle in each class must participate in number of pulls as follows:

VTPA Events		5	6	7	8	9	10	11	12	13	14	15	16	17	18
Must Pull			4	5	6	7	7	8	9	10	10	11	12	13	13

To be eligible for a season plaque, members must have participated in 51% or more pulls for that season.

7. All pulls will operate with a flagman, who is the Track Judge. This person is responsible for track readiness, contestants and sled.
8. Track Judge will have two flags: one green to start the contest and one red to stop or disqualify (DQ) contestants. Contestants must stop immediately upon judges' signal with the red flag.
9. The first puller in every class has the option to take the first pull or ask for a re-pull and drop back to third place and pull again. Re-pull option to be determined per event. If the sled needs further adjustments, the class will start over with the first puller. All requests for re-pulls must be made by the driver to the track judge before the vehicle is unhooked from the sled. Any disqualification on the first attempt bars a second attempt. The second puller in the class takes first puller position but does not get the re-pull option. Third position is after the first and second pullers are measured

## **EVENT PROCEDURES and POINTS - CONT'D**

10. During a pull-off, each contestant must pull in their original pulling order. There are no re-pulls during a pull-off. Each puller must make a measurable pull or will receive the same points as last place of the pull-off. Any disqualification or mechanical breakage will result in last place of the pull-off. Any ties for first place will pull against each other to break the tie. All other ties will split points. The coordinator and track judge will set the distance to establish a full pull.
11. A driver has 2 minutes to get his vehicle in place and ready to pull. If a driver is having mechanical problems only, and cannot make it in 2 minutes, he has the option to be moved to the back of the class
12. All pulls must start with a tight chain; no jerking permitted at any time during the pull. Rule compliance to be determined by the flagman (track judge).
13. Pullers are allowed two attempts within 75 feet to start the sled, unless the sled stops the vehicle. On a restart, puller must stay on vehicle and cannot make any weight changes for second attempt.
14. The vehicle (not sled) must remain within the track boundaries or vehicle will be disqualified.
15. All drivers MUST attend the drivers meeting.
16. A puller has the option to have the track redone (within reason) by asking the track judge.
17. All decisions by the Track Judge are final: He cannot be protested. Any attempts to do harm to any VTPA official will result in suspension for 60 days and loss of all points up to then. A second attempt will be "Good Cause" to be expelled for a period of "One year and one month".
18. Any protest should be brought up immediately and recorded at the pulling event in which protest occurred. Recorded protest will then be brought up at the next directors meeting.
19. If there is only one vehicle competing in a class, no re-pull is allowed.
20. Members will be assigned to the work crew at pulls on a rotating basis. Any member failing to work as assigned will lose points for the day and possible loss of membership for repeated failures.

**NOTE: All vehicles should be able to make back-to-back pulls.**

## **SECTION III: CLASS SPECIFIC RULES**

1. Stock Tractors are agricultural tractors having a standard block and crankcase for make, model and year entered. Chassis must conform to engine being entered. (Chassis includes clutch housing, transmission housing, differential housing and final drive housing). Internal and external factory replacement for block, crankcase and other parts are to be for the make, model and year of the tractor entered.
2. Any Puller (either member or non-member) that is allowed to pull as exhibition must fit vehicle into a regular established VTPA class within a maximum of (3) pulling events or will not be allowed to compete further.

## A. VTPA SANCTIONED WEIGHT CLASSES ARE:

1. Weight classes for **Stock Tractors** any year model is:

4,000 lbs	6,000 lbs	8,000 lbs	10,000 lbs
12,000 lbs	15,000 lbs	12,000 lbs OPEN	(refer to section “M”)

Stock tractors maximum horsepower output must not be over 25% of Manufacturers rated PTO horsepower. Tractors will be pulled down on the Dyno until maximum horsepower is obtained or tractor exceeds rated horsepower by more than 25%. RPM maximum is 25% above factory.

2. Weight classes for **Antique Stock Tractors** manufactured in 1959 or earlier are:

3,400 lbs (24hp)	4,000 lbs	4,500 lbs	5,500 lbs
6,500 lbs	7,500 lbs	9,000 lbs	

Maximum horsepower in Antique classes is (1) horsepower for each 100 lbs. of class weight. No shifting of TA's in Antique classes.

3. Weight classes for **Antique Farm Stock Tractors** are:

4,600 lbs	6,000 lbs
-----------	-----------

Refer to section “J” for class specific rules.

4. Weight classes for **Pro Stock Tractors** are:

7,500 lbs. (must follow N.T.P.A rules - including hitches)

5. Weight classes for **Antique (100hp maximum) Tractors** are:

6,400 lbs.- Refer to Section “K” for class specific rules.

6. Weight classes for **Modified (big block) Tractors** are:

5,800 lbs. (500 cubic inch limit)

7. Weight classes for **Small Block Modified Tractors** are:

5,600 lbs	4,500 lbs
-----------	-----------

Refer to item #M for class specific rules.

8. Weight classes for **Super Stock 4x4 Pickups** are:

6,000 lbs (Refer to VTPA Truck Rules)

## B. PTO RATED HORSEPOWER and DYNO

1. Maximum RPM's cannot be over 25% of maximum factory rated RPM's. A/C and all horsepower robbing accessories must be turned off while tractor is being dynoed.
2. The tech team officials are in charge of the dyno and pit area. They will check vehicles for rule compliance. Tech team officials' decisions are final and cannot be protested.

3. Only properly trained members will be allowed to operate the VTPA dyno. They will be responsible for Dyno at all times.
4. In the event the dyno malfunctions, the tech team officials can check RPM's by using a mechanical tachometer on tractors PTO shaft, use the tractors own tachometer or use an electric tachometer on the tractors flywheel or front vibration dampener pulley.
5. The first place winners in every class are to be dynoed, weighed and hitch will be measured. If not legal, the next in line and so forth will be checked until a legal vehicle is found. (Vehicle operator is responsible for having tractor available at the dyno.) Any class participant may call any member within the class to the dyno, at a pull within a reasonable time.
6. The 1<sup>st</sup>, 2<sup>nd</sup>, and 3<sup>rd</sup> place tractors must remain in the holding area or will be DQ'd. This rule also applies to the Super Stock 4x4 class.
7. All tractors must have a PTO for the dyno and a serial number for the I.D. of year of manufacture. The PTO must work properly or the tractor will be disqualified.
8. Any person entering an uncommon tractor must submit documented proof of rated horsepower, shipping weight and RPM's with entry form.
9. All governor and throttle adjustments must be secured with mechanics wire or locked with jam nut

### **C. TIRE SIZE**

1. There is no limitation on the front tire size. Unless otherwise stated in specific class rules, there is no limitation on rear tire size. Rear tires must be stock tractor tires and cannot be modified or cut what so ever. Cut tires are allowed in the following classes: Antique Farm Stock, Pro Stock, 100hp, and Modified classes.

### **D. WEIGHTS**

1. Front weights and weight bar cannot extend more than 24 inches in front of the tractor, such as hood, radiator or front tires.
2. Rear weights or weight bracket cannot extend more than 12 inches past the rear tires.
3. No weights will be allowed inside the vehicle cab. No weights are allowed on the vehicle floorboards, or anywhere else that may interfere with the safe operation of the vehicle.
4. Any weights or other objects falling from the vehicle while hooked to the sled will disqualify the vehicle.
5. All weights must remain in a locked position during entire length of pull.

### **E. BRAKES**

1. All vehicles must be equipped with working brakes.

**Figure A**

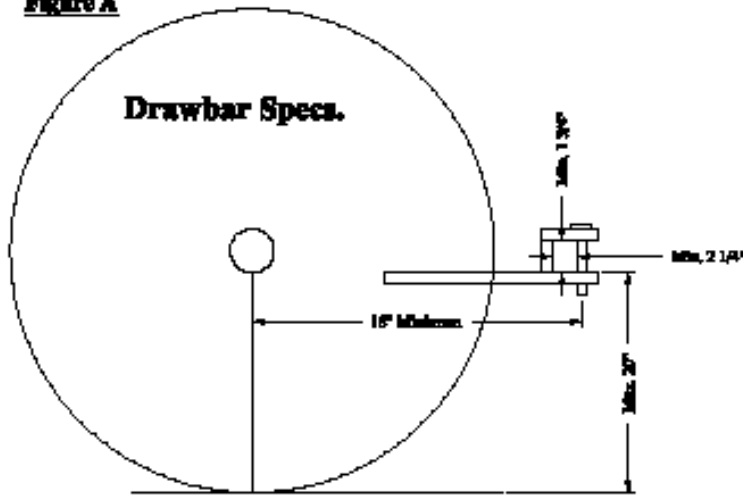

**Figure B**

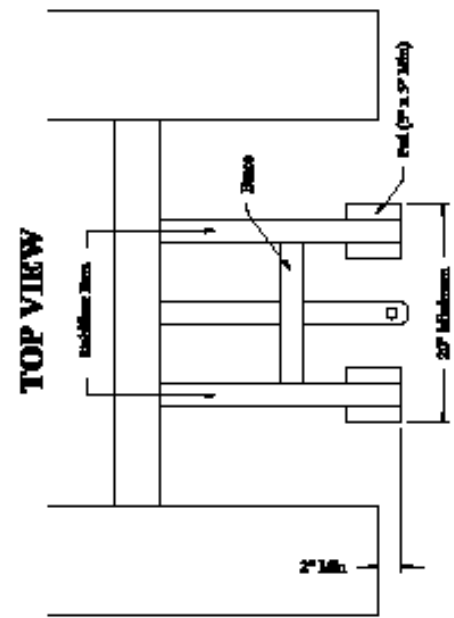

**Figure C**

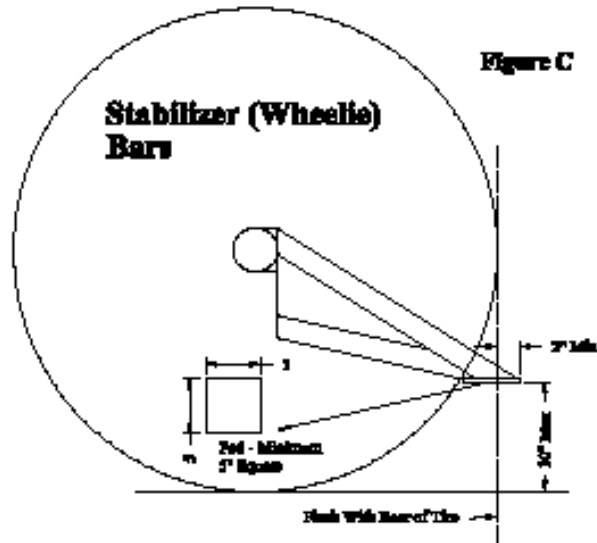

**Figure D**

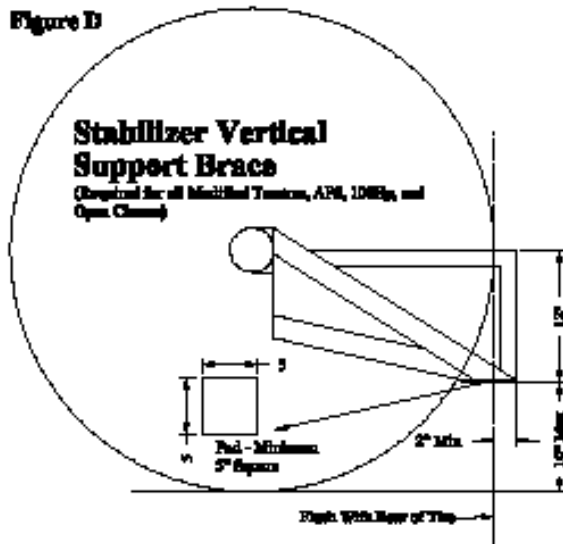

The stabilizer bar system must be able to support the weight of the tractor in the heaviest class pulled. Jacking up the pads so the tractor is completely off the ground is a good test of the strength of the systems support ability.

## F. DRAWBARS and HITCHES (Figure A)

1. The drawbar should be stock for the tractor entered, of similar quality of strength and size. Drawbar minimum length shall be at least 18 inches from the center of the rear axle to center of drawbar pin hole and shall be a double lip type. Maximum drawbar pulling height to ground is 20 inches. The opening between the double lips shall be at least 1-¾ inches; the drawbar pin size minimum is 7/8". A 2 ¼" minimum clearance from the inner diameter of pin to inside where top and bottom lips meet. Drawbar must be stationary in all directions. Drawbar pin must be hardened steel pin or equivalent to a red top pin or grade 8 pin or bolt. No sliding drawbars, or pins or trick hitches allowed. Hitch must not be hooked to hydraulics. A loop hitch must be horizontal.
2. No tolerance on hitch height
3. Ring type hitch OK
4. Drawbar maximum width is 3 inches.
5. Must be double lip for pin

## G. STABILIZER (Wheelie) BARS (Figure B, C & D)

1. The back of the Stabilizer pad must extend a minimum of 2 inches behind a line drawn from the back (center) of the wheel to the ground.
2. The Stabilizer pad must not be more than 10 inches off the ground.
3. The Stabilizer pad must be a minimum of 5 inches square measured across the top of the pad with a minimum of 20 inches allowed from the outside of one pad to the other.
4. Stabilizer bars must be mounted in two points. One of the two points may be mounted to the drawbar assembly.
5. There must be a horizontal brace that connects the two stabilizer bars together.
6. All tractors with center (top) link on hitch must be equipped with stabilizer bars.
7. The stabilizer bar system must be able to support the weight of the tractor in the heaviest class pulled. Jacking up the pads so the tractor is completely off the ground is a good test of the strength of the systems support ability.
8. Modified Tractors - Antique Farm Stock, Antique 100 hp, Small Block Modified, Big Block Modified, Pro Stock and 10,000 Lbs and up classes (Figure A, B, C & D)
  - a) Stabilizer bars are required regardless of hitch
  - b) In addition to the Stabilizer bars, there must be a brace that extends vertically 12 inches from the rear most tips of the skid pads.
  - c) There must be a support brace extending inward to frame, axle or top of stabilizer bar arms.

- d) Vertical brace should extend rearward a minimum of 2 inches from radius of rear tire.
- e) On Modified Tractors where the hitch and wheelie bars are connected to the same frame, the Stabilizer bars must be fastened at least 4 inches ahead of hitch.

## **H. FRONT WHEEL DRIVES**

1. Tractors having front wheel drives or assists will be allowed to pull but must have front drive disengaged.

## **I. SAFETY RULES**

1. Any vehicle left unattended by more than 10 feet with engine running will be disqualified (DQ'd).
2. There will be no hot roding in the pits or track area.
3. Vehicle must be in neutral and driver with hands raised before hook is attached or unhooked.
4. Pro Stock and Modified V-8 Tractors must comply with all N.T.P.A Safety rules.
5. No alcohol allowed on Track or in Pit areas. Violation will be reason for disqualification and/or loss of points.
6. All tractors with center (top) link on hitch must be equipped with stabilizer (wheelie) bars. (refer to Stabilizer bar diagram page 11)
7. Antique Farm Stock, Pro Stock, V-8 Modified, and Open classes require kill switches, fire extinguishers, and helmets with a Snell 95 or better rating. The helmet requirement is optional for the Antique Farm Stock class.
8. If equipped with electric fuel pump, must be wired to kill switch.
9. VTPA strongly recommends fire suits and seat belts.

## **J. ANTIQUE FARM STOCK RULES**

1. No turbos in antique class
2. No exotic fuels (only gas, diesel or propane)
3. Must run antique block – 1959 or older.
4. No RPM limit ( Dead Man throttle required)
5. No Dyno check
6. No automotive parts (electrical parts ok. Includes ignition, fans)
7. All Farm Stock tractors must appear stock.
8. Only one pump
9. May use any tractor part as long as it bolts on tractor with direct replacement (no adapter plates)
10. Any addition to tractor that is questionable MUST be approved by Tech Team

11. Tech Team will have the authority to require a tractor to have a safety cover, kill switch, or whatever they feel is necessary for safety.
12. Must run wheelie bars no higher than 10 inches
13. Hitches must comply with NTPA Rules

#### **K. 6400 LB ANTIQUE 100 Hp Class**

1. No turbos in antique class
2. No exotic fuels (only gas, diesel or propane)
3. Must run antique block – 1959 or older.
4. Dyno check
5. No automotive parts (electrical parts ok. Includes ignition, fans)
6. Tractors must appear stock.
7. Only one fuel injection pump allowed
8. Only one carburetor allowed
9. May use any tractor part as long as it bolts on tractor with direct replacement (no adapter plates)
10. Any addition to tractor that is questionable MUST be approved by Tech Team
11. Tech Team will have the authority to require a tractor to have whatever they feel is necessary for safety.
12. Must run wheelie bars no higher than 10 inches
13. Hitches must comply with NTPA Rules
14. No RPM limit

#### **L. SMALL BLOCK V-8 MODIFIED CLASSES – 4500 LBS. & 5600 LBS.**

The following general rules apply to both weight classes, however, those *rules that are specific to the 4500 Lb. class are shown in bold italics.*

1. ENGINE - any small block with a maximum of 60/1000<sup>th</sup> overbore with stock stroke crankshaft: no Chevy 400. Example: 350 engine must have 350 crankshaft. Must use flat tappet hydraulic camshaft only. Small blocks that qualify: 6.0 Liter engines, Chevy, Chrysler, Pontiac, Ford, Buick, or Oldsmobile...other engines must be approved by the board of directors.
2. NOT ALLOWED - after market roller lifters or solid lifters, aluminum heads, Nitrous fuels, compressed fuels, alcohols, turbos, linco transmissions, crower clutches (slipper type)
3. CARBURETORS - one carburetor allowed (throttle must be spring to idle. *4500 lb. class may use either a 2 bbl or 4 bbl carburetor with maximum 650 cfm .*
4. WHEELBASE - tractor length may not exceed 12 feet from center of the rear axle to furthest point in front, including weights. *Tractor length in the 4500 lb. Class must be no more than 10 feet from*

*center of the rear axle to furthest point in front, including weights.* Must have hood, grill and general tractor appearance. Seat must be stationary and have a backrest.

5. TRANSMISSION - transmission must be automotive production automatic or manual. Stock type clutches are allowed but only if using an SFI-G-1 rated bell housing.
6. SHIELDS - must have the following shielded with a minimum 1/16<sup>th</sup> thickness of steel: Transmission, all transmission couplers, belts and pulleys (on their plane of rotation).
7. TIRES - there is no limitation on front tire sizes. Rear tires cannot exceed 24.5 x 34, and may be cut. ***Rear tire size in the 4500 lb. Class cannot exceed 18.4 x 28 inches with a maximum width of 22 inches and may not be cut.***
8. WHEELIE BARS, WEIGHT BRACKETS, and HITCHES - construction, design and specifications must conform to general VTPA guidelines. Maximum Hitch height is 20 inches in the 5600 lb. Class. ***Maximum Hitch height in the 4500 lb. Class is 18 inches.***
9. SAFETY EQUIPMENT - both classes are subject to the general VTPA safety rules. Must have the following additional safety equipment as follows: Wide Front End, Fenders, Kill Switch, Neutral Hook Lamp, Dead Man Throttle, Seat Belt, and on board Fire Extinguisher. Driver must wear seat belt and helmet (Snell 95 or better). ROLL CAGES and FIRESUITS are not required but highly suggested.
10. NO TOP LINKS

**M.12,000 LB. "OPEN" STOCK CLASS ADDITIONAL RULES:**

1. Engine must be stock or OEM stock replacement engine.
2. One Turbo allowed but must be no more than 2.80 inch inlet and outlet size.
3. RPM limit is 3,000. RPM's can be checked by electronic hand held unit at front pulley if necessary.
4. No horsepower limitation
5. No Water Injection. Fuels (other than stock fuels of the tractor) or any trick fuels or boosters of any kind are not allowed.
6. There is no limitation on rear tire size, however, tires may not be cut.
7. Driver must wear seat belt and helmet. (Snell 95 or better rating)
8. Tractor must have factory ROPS or a roll cage.